

Water hose reel robot

QSJ1200-T

Safety, Operation, and Maintenance

User Manual

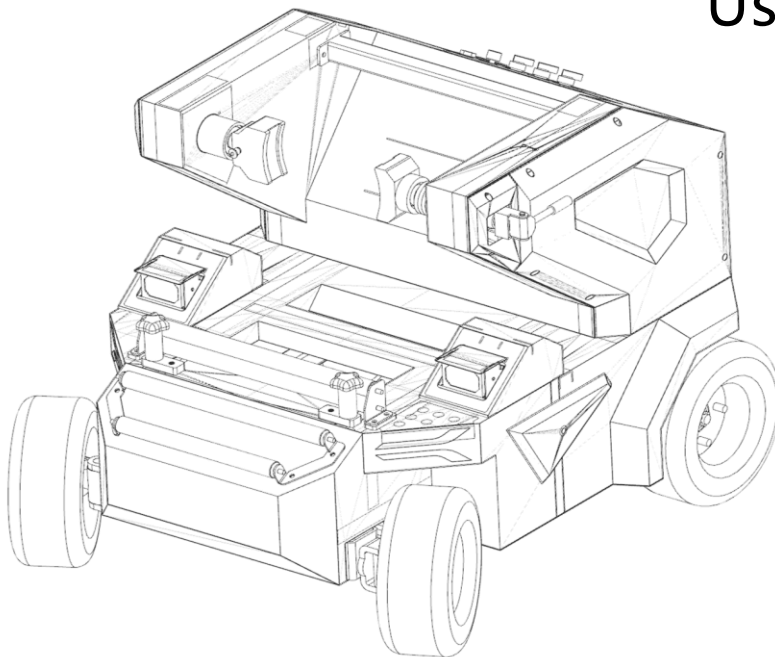

T a b l e o f c o n t e n t s

Chapter 1 Security 1

 1.1. Security symbol 1

 1.2. Safety Notice 2

Chapter Two: Product Introduction 4

 2.1. Product Structure 4

 2.2. Three-dimensional dimensional drawing 5

 2.3 . Technical parameters 5

Chapter 3 Operation 7

 3.1. Preparations before operation 7

 3.1.1. Engine crankcase oil level 7

 3.1.2. Engine fuel level 7

 3.1.3. Hydraulic oil 8

 3.1.4. Battery 8

 3.2. Operation 8

 3.2.1. Local start-stop engine 8

 3.2.2. Touchscreen control device 9

 3.2.3. Remote control start/stop engine 10



 3.2.4. Remote control device 10

3.2.5 . Shut down the device	11
3.2.5.1 . Touchscreen to turn off device	11
3.2.5.2 . Remote control to turn off the device	11
Chapter 4 Maintenance and Care	12
4.1. Fuel System Inspection and Maintenance	12
4.2. Hydraulic System Maintenance	12
4.3. Store	12

Chapter 1 Security

1.1. Safety symbol

When operating, maintaining, and repairing equipment, pay attention to the symbols and markings on the following equipment. Ignoring these warnings may result in serious personal injury or death, as well as equipment damage.

symbol	project	Remark
	Be careful not to pinch your hand.	Personnel should be warned of the risk of hand pinching during operation due to localized mechanical movement.
	Be careful not to get involved.	Personnel should be warned of the risk of hand pinching during operation due to localized mechanical movement.
	be safe	Be vigilant about minor dangers, as they could potentially lead to minor or moderate injury if not avoided.

Please comply with the safety requirements and precautions marked above to avoid unnecessary personal injury and equipment damage.

Local safety regulations: Please fill in the relevant local safety laws and regulations in the table below as supplementary information to the safety operation instructions in this manual. Operators and maintenance personnel must also comply with these regulations.

1.2. Safety Precautions

Operators, equipment maintenance, and repair personnel must comply with the safety operating instructions in this manual (including the safety instructions on the labels of the equipment and pipelines).

Follow safety operating instructions to ensure personal safety. Before operating the equipment, carefully read the safety instructions.

Enterprise safety supervisors should add relevant safety production content to this safety instruction booklet based on the characteristics of their region and fill it in the corresponding columns.

1. Personnel not authorized to perform the work are prohibited from entering the work area. Flying debris can cause personal injury. Operators must be familiar with hazardous work environments, such as exceptionally steep ramps.
2. Establish a system for training operators before they are allowed to work.
3. Do not operate the equipment until you have fully mastered its operation or when no safety supervisor is present.
4. Operators must wear appropriate personal protective equipment such as masks, safety helmets, safety shoes, ear protectors, and goggles when working.
5. When using a robot-driven hydraulic tool, do not perform any maintenance on it while it is running, as any accident caused by this may result in serious personal injury.
6. Before using the tool, double-check that the oil pipe connection is correct.
7. Robots cannot be operated in enclosed spaces because the exhaust fumes from the engine could cause poisoning or suffocation in people.
8. When there is water-related work, it is prohibited to work above the water level.
9. When using a winch, it must be securely tied, and it is strictly forbidden to use it beyond the specified traction force.
10. Robots should not carry people to prevent accidents.
11. The robot is quite large, so you need to keep an eye on the surroundings of the equipment to avoid blind spots and make sure there are no dangerous factors before operating it.
12. When cleaning the robot, do not use a water hose to directly rinse the part above the wading mark to prevent damage to the components. Instead, wipe it with a damp towel that is not dripping wet.
13. When climbing steep slopes, it is forbidden to work beyond the overturning angle to prevent the equipment from tipping over.
14. When working on ground with an angle of instability, use a small throttle and drive slowly to prevent accidents.
15. When the robot is moving around, first check if the water pump has risen to its

highest point to prevent it from getting scratched during movement.

16. Do not place items on top of the device while it is in use.
17. Do not add fuel to the equipment while the engine is running or has just stopped.
18. Do not use flammable solvents to clean engine surfaces.
19. After using the robot, allow the engine to cool down naturally before driving it back to the warehouse.
20. The maintenance and repair of hydraulic tools must be performed by professionals authorized by the company.
21. Do not use hydraulic tools on dangerous slopes or other unstable locations to avoid the equipment tipping over during operation.
22. Do not use tools beyond the scope of the design.
23. Robots must be operated in a well-ventilated environment and must not be used in places with explosion hazards, enclosed spaces, or near flammable materials.
24. inspecting the robot's electrical components, please disconnect the starting battery; otherwise, the electrical circuit may be burned out.



Chapter 2 Product Introduction

The QSJ1200-T drainage robot was developed to improve the efficiency of flood control and drainage. The equipment adopts wireless remote control operation with a remote control distance of over 300 meters, allowing personnel to complete the emergency operation away from the danger zone and greatly ensuring personnel safety. The equipment can be selected in two walking modes, tracked and wheeled, depending on the application.

The QSJ1200-T drainage robot is equipped with its own engine, allowing for continuous long-term operation on a full tank of fuel. Diesel or gasoline engines are available. The equipment is hydraulically driven, ensuring safety and reliability, and can operate without a power supply. The robot features a high-flow-rate drainage pump, enabling large-volume, long-distance water delivery. Additionally, a hydraulic output port can be added to power various hydraulic tools. It is suitable for drainage operations in urban underground parking garages, underground passages (the equipment can descend stairs), highway tunnels, culverts, subways, and other low-lying areas unsuitable for human access .

2.1. Product Structure

The QSJ1200-T uses a built-in engine to power the robot, allowing for extended operation on a single fuel fill. The entire machine utilizes hydraulic principles for water pumping and movement, and its tracked mechanism enables it to handle complex working conditions. Two high-flow-rate drainage pumps are built into the robot's base, enabling long-distance, high-volume water delivery. The equipment also features a multi-stage hydraulic cooling system for reliable, extended operation. To handle emergencies, an electric winch and two external hydraulic output ports are included, facilitating more efficient rescue operations.

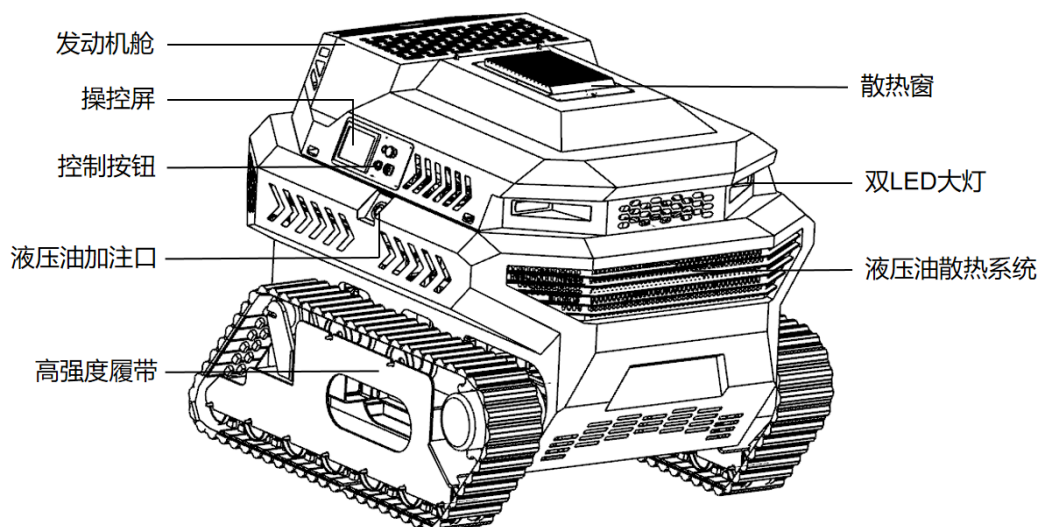

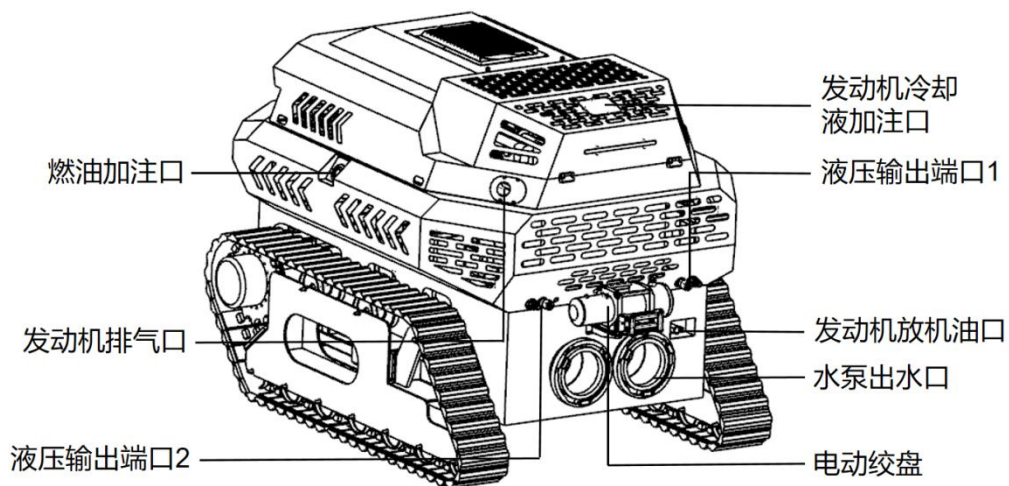

2.2. 3D dimension drawing

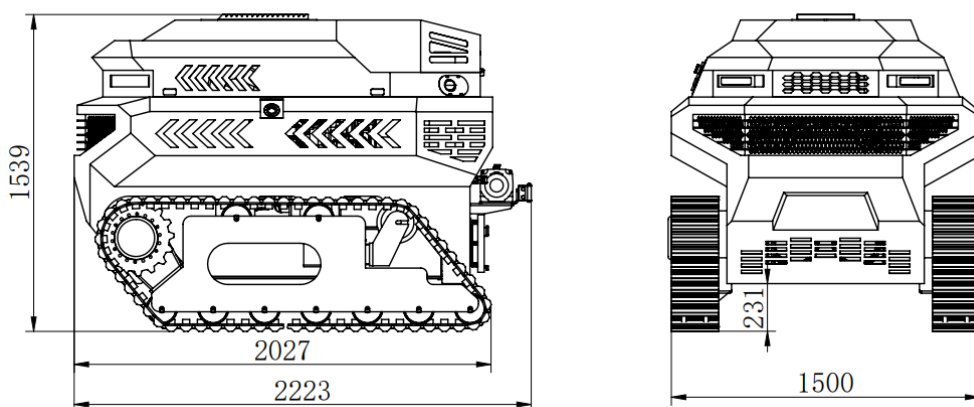

2. 3. Technical parameters

QSJ1200-T	
Engine power	81kw/diesel engine
External dimensions (mm)	2220*1500*1500
Weight (kg)	1590

Discharge rate (m³/h)	Measured value: Maximum drainage 1200±8%
Maximum head (m)	Measured value: 1.5 ± 5%
Number of water pumps	2
water pump inlet diameter	200mm
Particulate matter	35mm
Fuel tank capacity (L)	50
Hydraulic oil tank capacity (L)	70
Hydraulic flow rate (lpm)	80-100 (adjustable)
External hydraulic output terminal	4 points/6 points
Work stress (bar)	180
walking style	track
Winch (lb)	6000
Walking speed (km)	≥2.5
Climbing angle	≥35°
lighting	2
Ground clearance (mm)	≥200
Obstacle clearance height (mm)	≥250
remote control	≥300m It uses a rugged remote control and is equipped with a parameter display screen.
Continuous running time (h)	≥8
Wading depth (mm)	≤650
Water alarm	yes
Liquid level alarm	yes
Temperature alarm	yes

Chapter 3 operate

3. 1. Preparation before operation

Do not operate or repair hydraulic tools until you have fully read and understood the performance characteristics of the equipment.

3. 1. 1. Engine crankcase oil level

Before each start-up, check the engine oil level. The engine oil level should be between the F and L marks on the dipstick, but not too full. Outdoor temperature determines the appropriate engine oil viscosity; please refer to the table below to select the optimal oil for your specific outdoor temperature range. Do not use any special additives.

Outdoor temperature determines the appropriate viscosity of engine oil. Use Table 4 to select the optimal engine oil for different outdoor temperature ranges.

Table 4 Optimal Engine Oil for Different Temperature Ranges

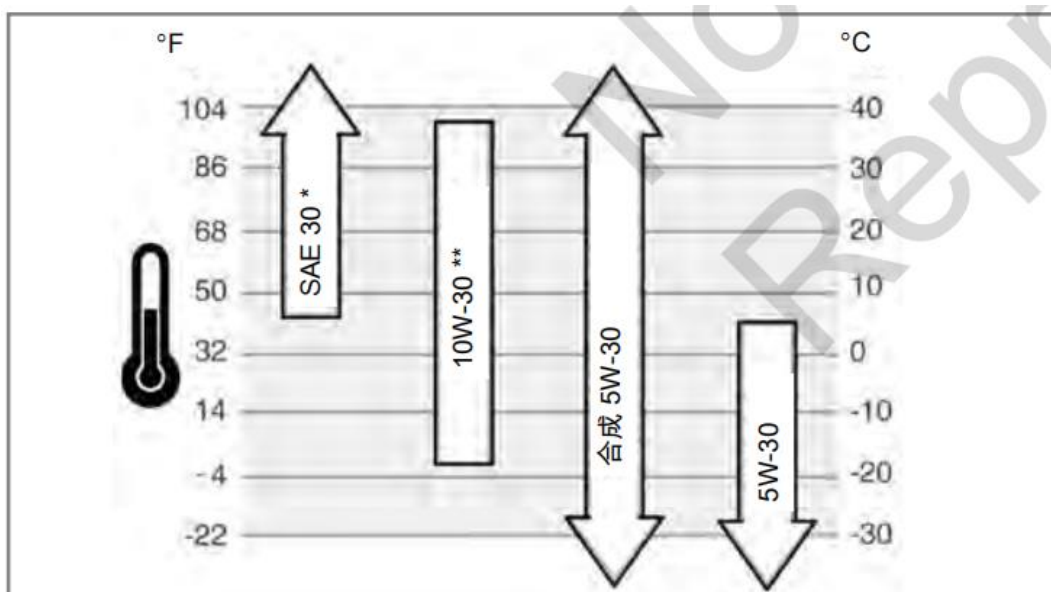

* Below 40° F (4° C), using SAE30 will result in difficulty starting.

**Using 10W-30 above 80° F (27° C) will increase oil consumption. Please check the oil level frequently.

3. 1. 2. Engine fuel level

Check the engine oil level and add clean, non-deteriorated fuel. It is recommended to

fill the fuel tank before each trip to use the hydraulic power station.

3. 1. 3. hydraulic oil

Check the hydraulic oil level and add hydraulic oil that meets the standards. The hydraulic oil viscosity must have a wide operating temperature range, allow moisture to separate and precipitate from the oil layer, and inhibit microbial growth. Hydraulic oils with other properties that meet or exceed these requirements also meet our usage requirements.

3. 1. 4. Battery

The battery is DC 24V, maintenance-free, and fully charged.

The cable must be tightly connected to the electrode and the connecting post.



When fully charged, the battery voltage should reach 24V - 28.6V . Overcharging the battery will cause it to overheat and damage it. If using an automatic charger, refer to the user manual.

3. 2. operate

3. 2. 1. Local start-stop engine



- 1、 Turn on the emergency stop switch.
- 2、 Turn the knob switch to the right until it is ON, and the display screen will light up.

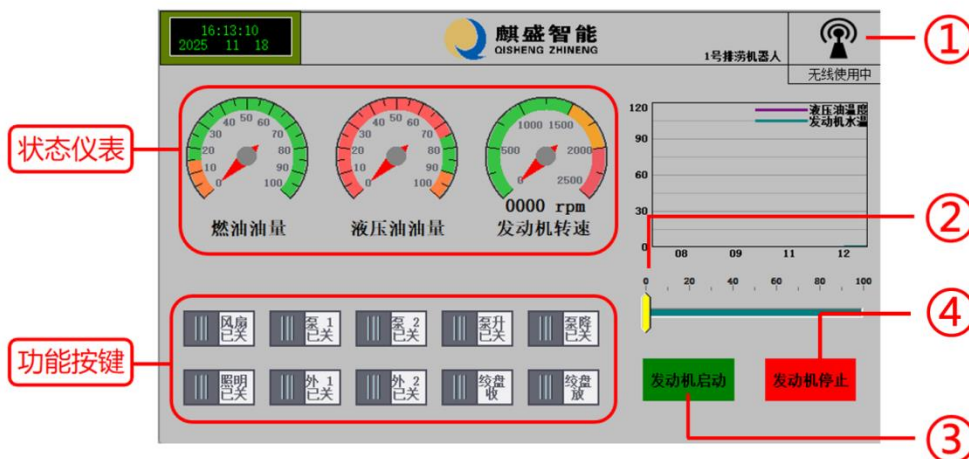

3、According to the order shown in the diagram above, ① first switch to local remote control mode.

4、Confirm that the throttle is at zero.

5、Press button ③ briefly to start the engine, and release the button immediately after the engine starts.

6、After the engine starts, slide ② to control the engine throttle.

7、Click ④ to stop the engine.

3.2.2. Touch screen control device

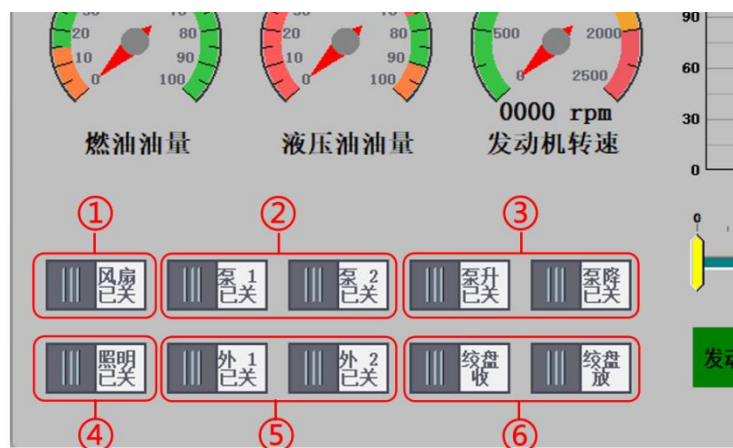

1. Control the switch of the hydraulic oil cooling fan.

2. Control the switches of the two drainage pumps of the equipment. After turning them on, the pumps will start working. Adjust the engine speed to regulate the water flow rate.

3. Control the rise and fall of the drain pump to lower the minimum drainage position.
4. Control of the robot's LED headlights.
5. Two sets of external hydraulic output terminals are controlled by switches to adjust the engine speed and regulate the hydraulic flow.
6. Control of the electric winch's raising and lowering.

3.2.3. Remote start/stop engine



- 1、Switch to ① Wireless Remote Control in the upper right corner of the device's touchscreen.
- 2、Turn on the emergency stop switch ② on the side of the remote control.
- 3、Press and hold the power button on remote control ③.
- 4、Press ④ briefly to start the engine, and release the button immediately after the engine starts.
- 5、Press ⑤ to turn off the engine.

3.2.4. Remote control device



- 1、Fluctuation ① The lever controls whether movement is allowed.
- 2、Use push rods ② and ③ to control the robot's forward movement and turning.
- 3、The levers ④⑤⑥⑦⑧ control the switches for the corresponding functions.
- 4、While driving, turning the throttle ⑨ controls the engine speed and adjusts the travel speed.
- 5、When pumping water, turning the throttle ⑨ controls the engine speed and adjusts the water flow rate.
- 6、When using the hydraulic output port, turning the throttle ⑨ controls the engine speed and adjusts the hydraulic output flow.

3.2.5. Turn off the device

3.2.5.1 Turn off the device via touchscreen

1. When stopping the machine, slowly slide the throttle to the minimum and wait for 5 seconds.
2. Click the close button for each function .
3. Click the engine off button .
4. Turn the knob to OFF to turn off the touchscreen.
5. Press the emergency stop button to cut off the power to the entire machine.

3.2.5.2 Remote control to turn off the device



- 1、 Turn the throttle knob ① to its minimum position and let the engine idle for 5 seconds.
- 2、 Raise the water pump to its highest point ②.
- 3、 Switch walking to prohibited walking ③.
- 4、 Move lever ④ to the middle position.
- 5、 Click the engine stop button (⑤) to turn off the engine.
- 6、 Press the emergency stop button on the remote control.

Chapter 4 Maintenance

Perform routine maintenance on the equipment in accordance with this manual, the accompanying engine user manual, and other relevant technical manuals.

4. 1. Fuel system inspection and maintenance

1. The fuel supply system needs to be inspected annually, and any parts found to be leaking oil should be replaced immediately.
2. Inspect the oil pipes, oil tank, joints, etc. for leaks, cracks, etc., and replace any faulty parts.
3. The replacement parts must be identical to the original parts, and their installation direction must also be identical to that of the original parts.

4. 2. Hydraulic system maintenance

1. Check the hydraulic oil level daily and add hydraulic oil as recommended in this manual if necessary.
2. Drain all the oil from the hydraulic oil tank and store it in a clean container.
3. After storing the extracted oil for a period of time, carefully pour the settled oil slowly into the hydraulic oil tank, being careful not to pour in water.
4. Check the hydraulic hoses and joints daily for leaks.
5. Hydraulic oil filters need to be replaced every 200 hours of operation. Be careful as dust and moisture can easily enter the oil; in such cases, timely replacement is even more necessary.
6. Inspect the hydraulic oil cooler. Blow away any debris from its surface with compressed air.

4. 3. Storage

1. Before storing the product, wipe the surface of the equipment clean. Do not use a high-pressure water gun to clean the equipment.
2. The equipment must be stored in a clean, dry place.
3. Check the hydraulic oil tank for water. If water is present in the hydraulic oil, replace it with the type of hydraulic oil specified in this manual.